

FRONT VIEW

15"X18" BOTTOM HINGED
A/D U.L. APPROVED
W/ RUBBER BAFFLE
(NTS)

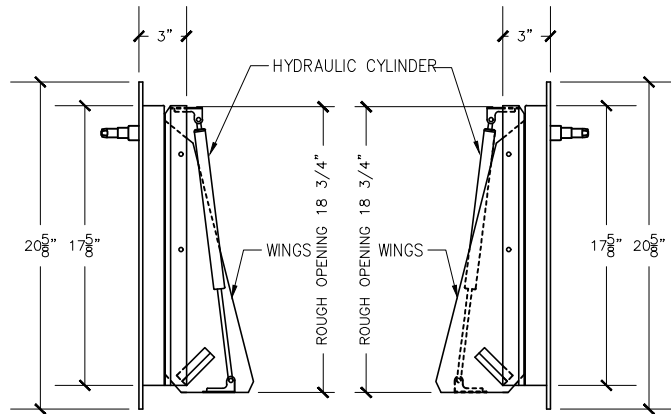

RIGHT VIEW

LEFT VIEW

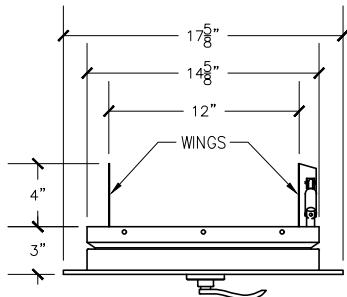

TOP VIEW

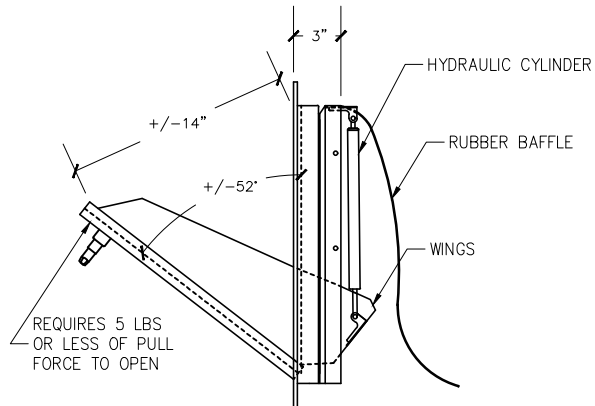

TRASH DOOR AT OPENED POSITION

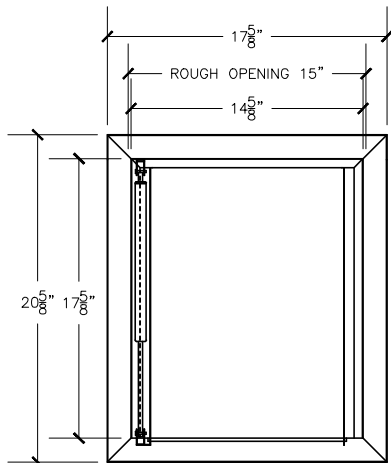

REAR VIEW

MODEL # 35B-ADA MEETS ANSI A117.1 REQUIREMENTS:
Doors are fabricated with type 304 Stainless Steel and Stainless Steel hinges. Construction includes a self closing, self latching quiet door closing function. Lever handle does not strain wrist during operation. Door requires less than 5lbs. of pull force to open.

Classified 'UL' Class B labeled: 1-1/2 hour fire rated with 30-minute temperature rise of 250 degrees Fahrenheit and a frame suitable for enclosing multiple type chase construction. Doors are provided with key locking devices at each intake door location. Door trim is embossed "**RUBBISH**".

NOTE:

Rough opening required 15"x18 3/4"

TRASH CHUTE INTAKE DOOR
MODEL # 35B-ADA 15"X18" TD/BH 1-1/2" TRIM

956 Brush Hollow Rd.
Westbury, NY 11590
phone: (718) 472-5700
fax: (718) 472-5813
website: www.allcitymetal.com
e-mail: info@allcitymetal.com

ALL-CITY METAL
SHEET METAL FABRICATORS