

RIGHT VIEW
RUBBER BAFFLE NOT SHOWN

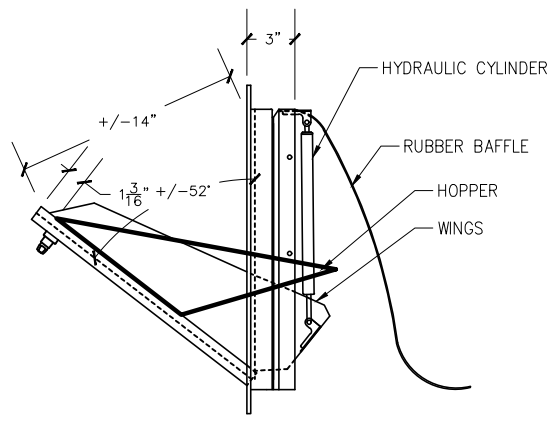

TRASH DOOR AT OPENED POSITION
WITH RUBBER BAFFLE

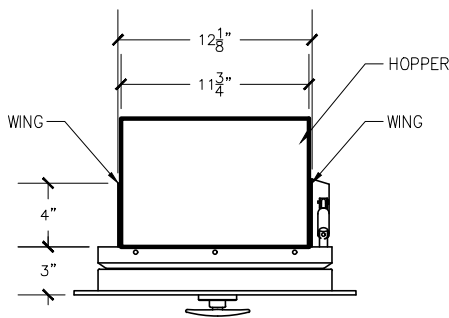

TOP VIEW
RUBBER BAFFLE NOT SHOWN

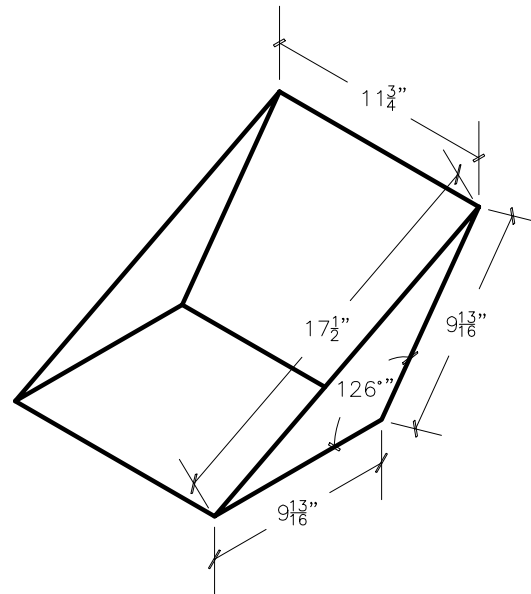

HOPPER DETAIL

Trash chute door specifications:

Doors are fabricated with type 304 Stainless Steel, Stainless Steel hinges, with a self closing, self latching quiet door closing function. Classified 'UL' Class B labeled: 1-1/2 hour fire rated with 30-minute temperature rise of 250 degrees Fahrenheit and a frame suitable for enclosing multiple type chase construction. Doors are provided with key locking devices at each intake door location. Door trim is embossed "**RUBBISH**".

NOTE:

1. Rough opening required 15"x18 3/4"
2. Hopper welded to door.

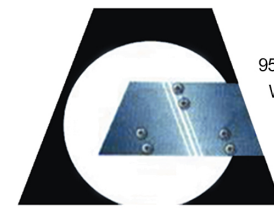

956 Brush Hollow Rd.
Westbury, NY 11590
phone: (718) 472-5700
fax: (718) 472-5813
website: www.allcitymetal.com
e-mail: info@allcitymetal.com

ALL-CITY METAL INC.
SHEET METAL FABRICATORS

**TRASH CHUTE INTAKE DOOR
W/ HOPPER**

MODEL # 35B 15"X18" TD/BH 1-1/2" TRIM/H