

FRONT VIEW

15"X15" BOTTOM HINGED
ACCESS DOOR
A/D U.L. APPROVED

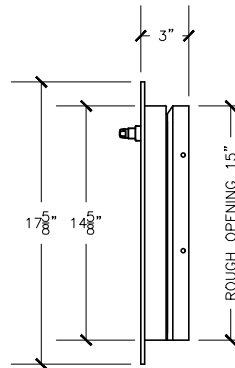

RIGHT VIEW

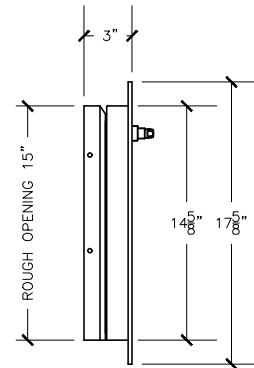

LEFT VIEW

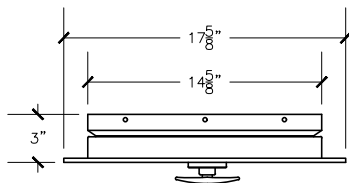

TOP VIEW

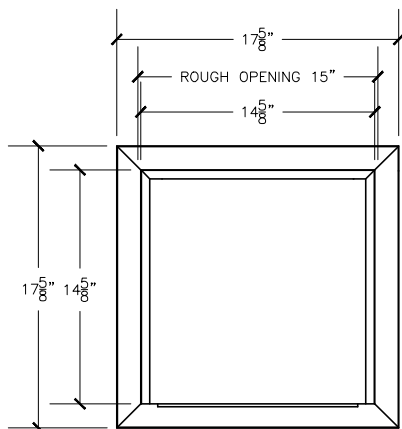

REAR VIEW

Access door specifications:

Doors are fabricated with type 304 Stainless Steel, Stainless Steel hinges, with a latching device equipped with an ADA compliant "T" Type Lever Locking Handle. Class B labeled: 1-1/2 hour fire rated with 30-minute temperature rise of 250 degrees Fahrenheit and a frame suitable for enclosing multiple type chase construction.

NOTE:

Rough opening required 15"x15-3/4"

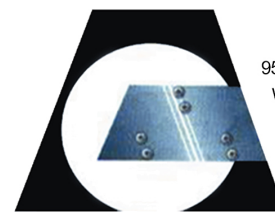

956 Brush Hollow Rd.
Westbury, NY 11590
phone: (718) 472-5700
fax: (718) 472-5813
website: www.allcitymetal.com
e-mail: info@allcitymetal.com

ALL-CITY METAL
SHEET METAL FABRICATORS

ACCESS DOOR

MODEL # 15AD 15"X15" AD 1-1/2" TRIM